

## 976nm Wavelength-stabilized Laser Diode

By adopting specialized fiber-coupling techniques, the manufactured diode laser modules have a high efficiency, stability and superior beam quality. The modules are achieved by transforming the asymmetric radiation from the laser diode chip into an output fiber with small core diameter by using special micro optics. Inspection and burn-in procedures guarantee reliability, stability and long lifetime of each modules.

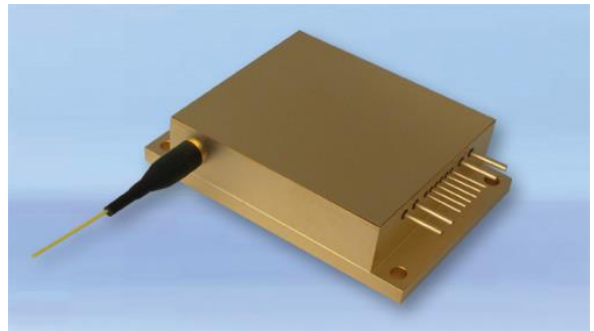

### Features

- 100W CW output power
- Narrow linewidth
- Feedback protection for fiber laser

### Applications

- Fiber laser pumping

### Package dimension (mm)

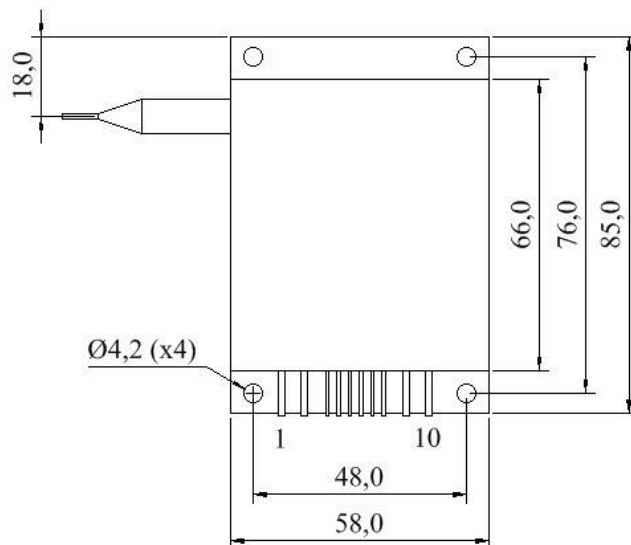
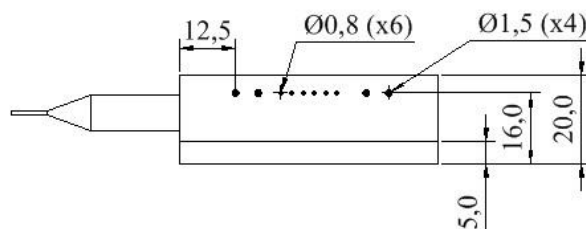
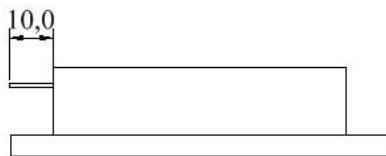

Pin	Function
1	Laser diode -
2	Laser diode -
3	Thermistor
4	Thermistor
5	Photo diode (P)
6	Photo diode (N)
7	NC
8	NC
9	Laser diode +
10	Laser diode +



## Module Specifications

Model	M976±0.5-100-F105/22-D1-P			
<b>Optical parameters</b>		<b>Unit</b>		
Output power	W		100	
Central wavelength	nm		976	
Wavelength tolerance	nm		± 0.5	
Spectral width (FWHM)	nm		< 0.5	
Wavelength temp. Coefficient	nm/°C		0.02	
Wavelength current coefficient	nm/A		0.05	
<b>Fiber parameters</b>				
Fiber core diameter	µm		105 ± 3	
Numerical aperture			0.22 ± 0.02	
Bare fiber length	m		1 or 2	
<b>Electric parameters</b>		<b>min</b>	<b>typical</b>	<b>max</b>
Threshold current	A		0.5	
Operating current	A	8.5	9.5	10.5
Operating voltage	V	24.0	25.0	26.0
Slope efficiency	W/A		11.8	
Power conversion efficiency	%	40	45	
<b>Back reflection protection</b>				
Wavelength range	nm		1030 – 1100	
Attenuation	dB		>40	
<b>Other parameters</b>				
Operating temperature*	°C		25 – 40	
Operating humidity	%		< 75	
Storage temperature	°C		-20 – +80	
Soldering temperature	°C		250 (10s)	

\* Internal thermistor reading

- Notes:
1. Module specifications and dimension are subject to change without notice.
  2. ESD precautions must be taken.
  3. The minimum fiber bend diameter should be 300 times greater than the fiber core diameter.
  4. Reduced lifetime if improperly used or used above operating conditions.
  5. A non-condensing environment is required for storage and operation below the ambient dew point.

**Compliance with Regulatory Requirements:** This industrial laser is an OEM version of a laser diode. As such, it is intended only for integration into other equipment. This laser does not comply with IEC and CDRH requirements. The customer is responsible for IEC and CDRH certifications of the system that incorporates this industrial laser.

